

**TRAIN BACK WALL**

NOTES: COVER WITH SCRIM. ALL MOLDING IS THREE DIMENSIONAL. WINDOWS WILL HAVE CURTAINS ON THEM. FLAT IS BUILT AS A HOLLYWOOD. SPECIAL ATTENTION NEEDS TO BE PAID TO THE PLACEMENT OF THE SUPPORTS TO MINIMIZE WOOD EXPOSURE BEHIND THE SCRIM.

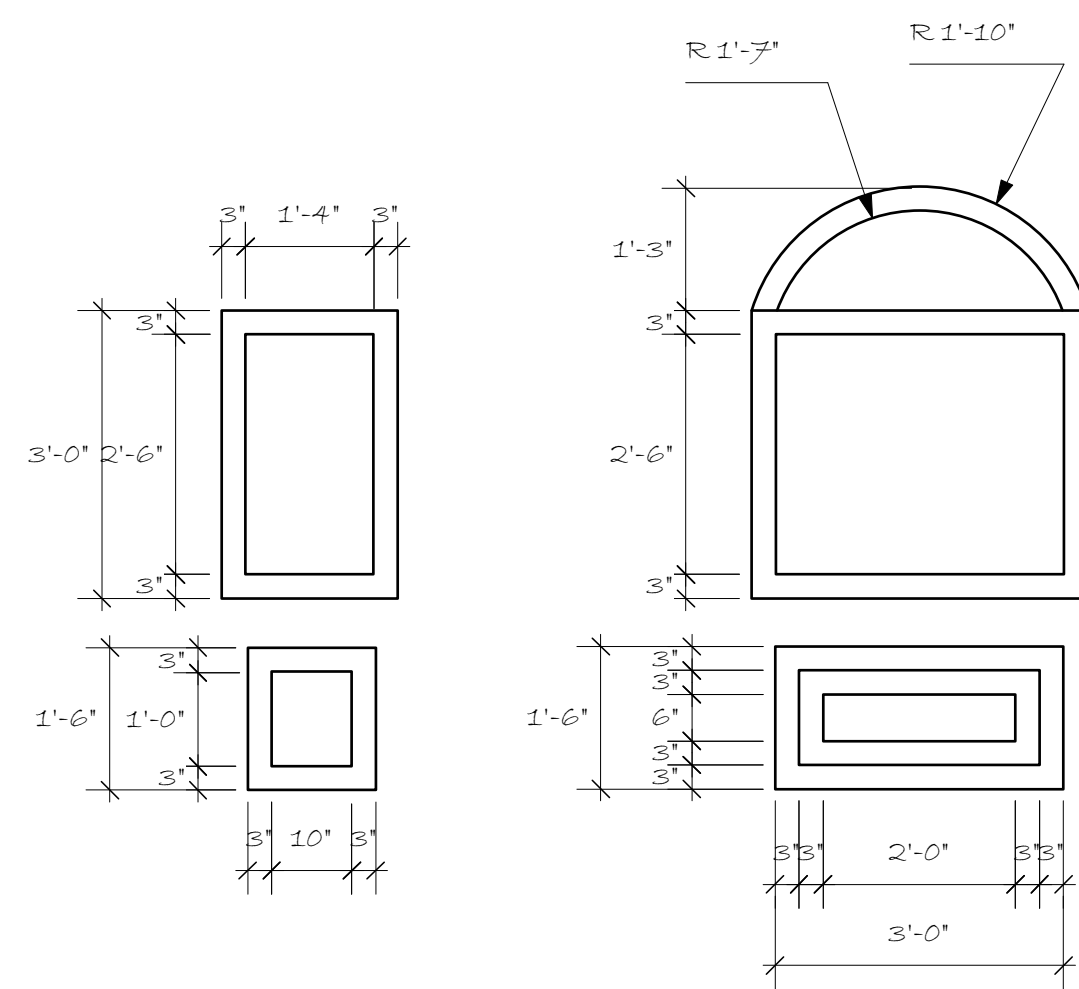

**WINDOW AND MOLDING PULLOUTS**

NOTES: THESE PIECES ARE BUILT INTO THE WALLS AND ARE NOT BUILT AS SEPERATE PIECES. THIS DRAWING IS TO CLARIFY MEASUREMENTS. SEE DESIGNER FOR MOLDING CHOICES.

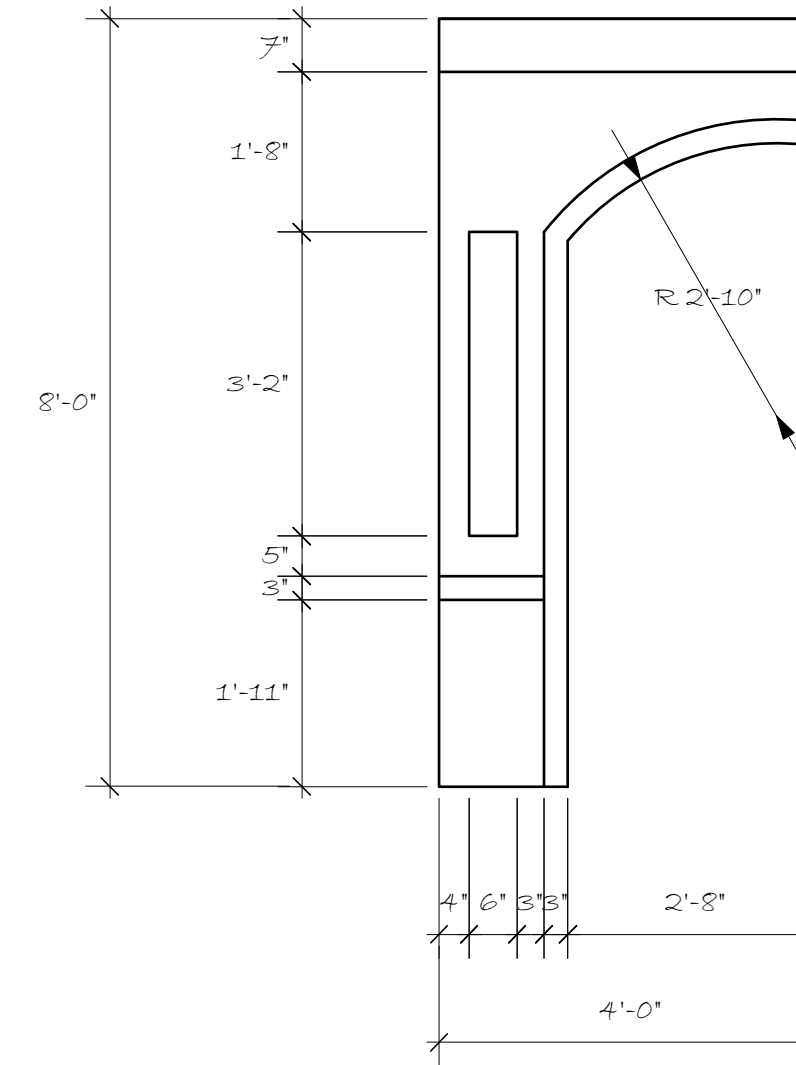

**TRAIN SIDEWALL**

NOTES: BUILD AS A HOLLYWOOD COVER WITH SCRIM. BUILD 2. ONE IN MIRROR IMAGE. SEE DESIGNER FOR MOLDING AND QUESTIONS.

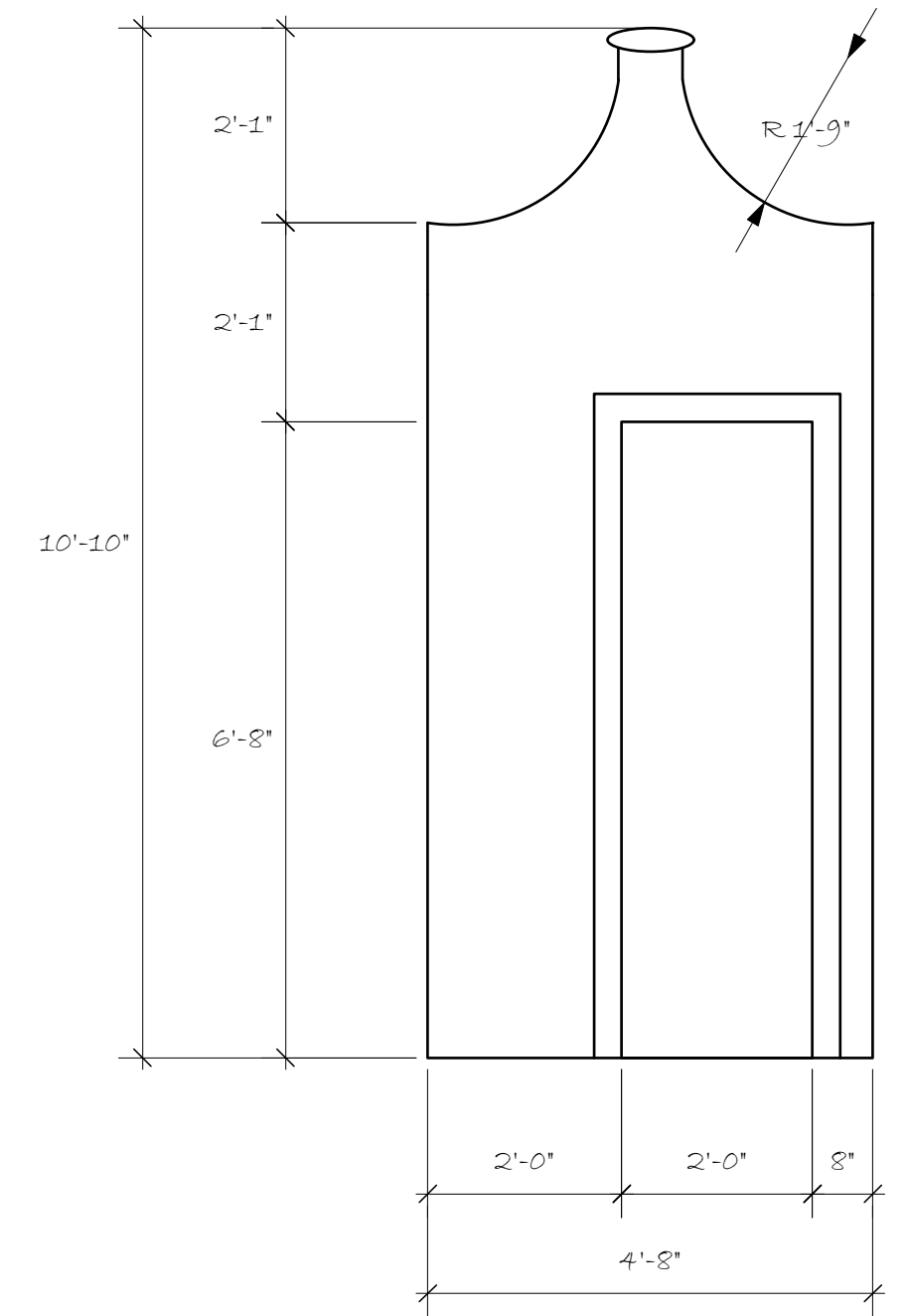

**SODA SHOPPE FASCADE**

NOTES: BUILD AS A HOLLYWOOD. COVER WITH VACUFORM BRICK. SEE DESIGNER FOR MOLDING AND DOOR.

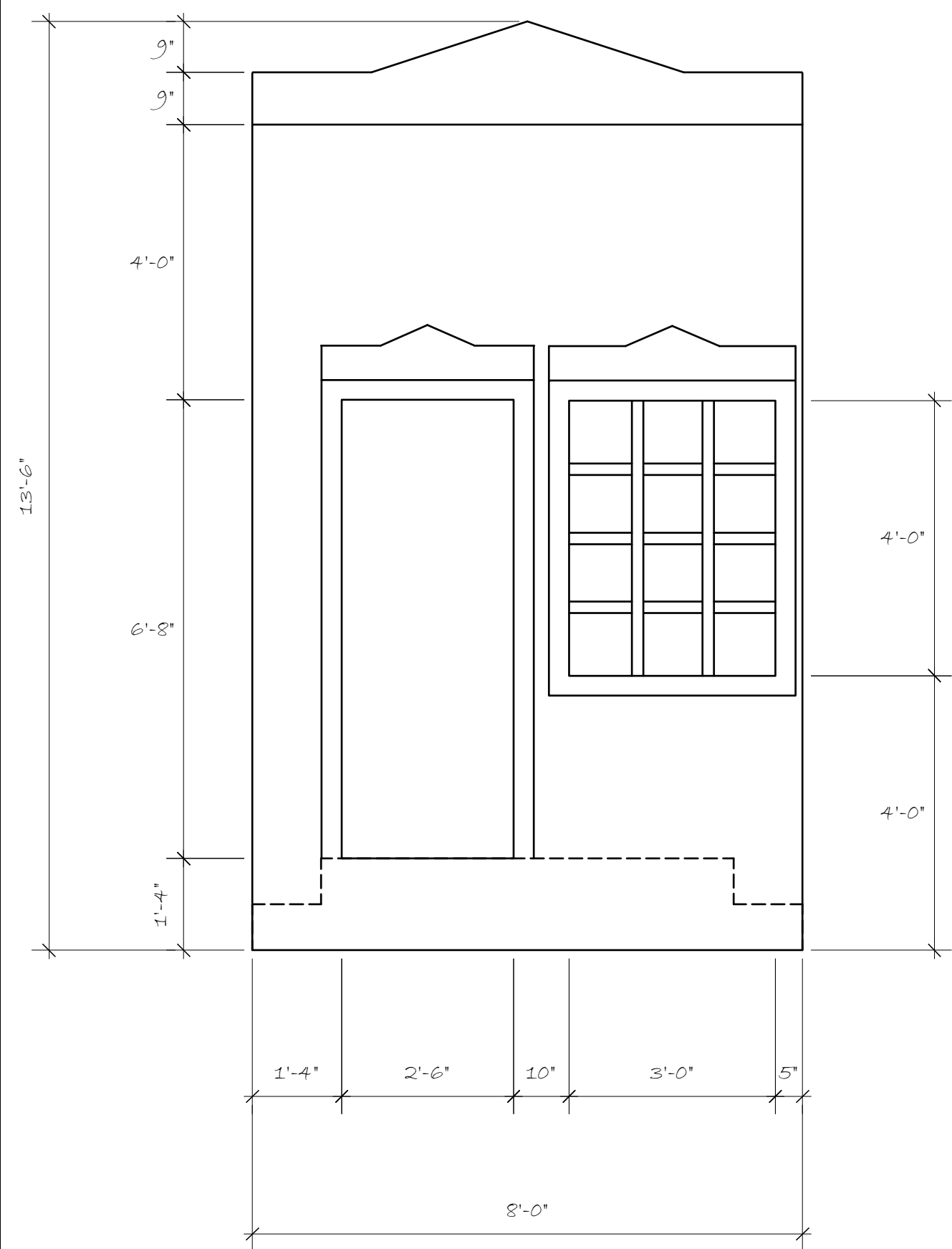

**GENERAL STORE FACADE**

NOTES: BUILD AS A HOLLYWOOD. FLAT FITS BEHIND THE SIDEWALK. WINDOW MULLIONS ARE OUT OF 1" FOAM. SEE DESIGNER FOR DOOR.

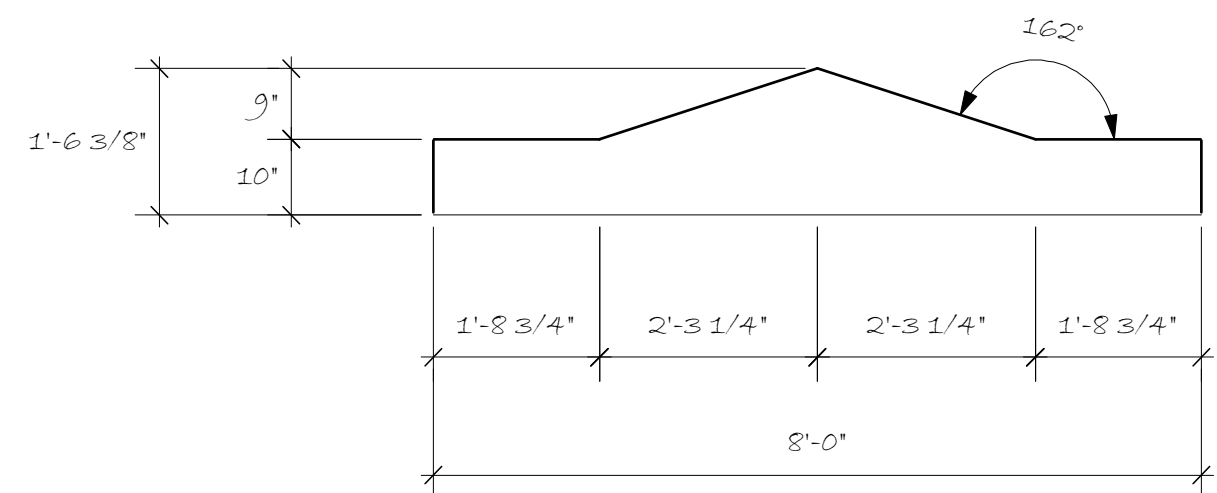

**BUILDING TOP DETAIL**

NOTES: BUILD AS A HOLLYWOOD AND COVER WITH LUAN

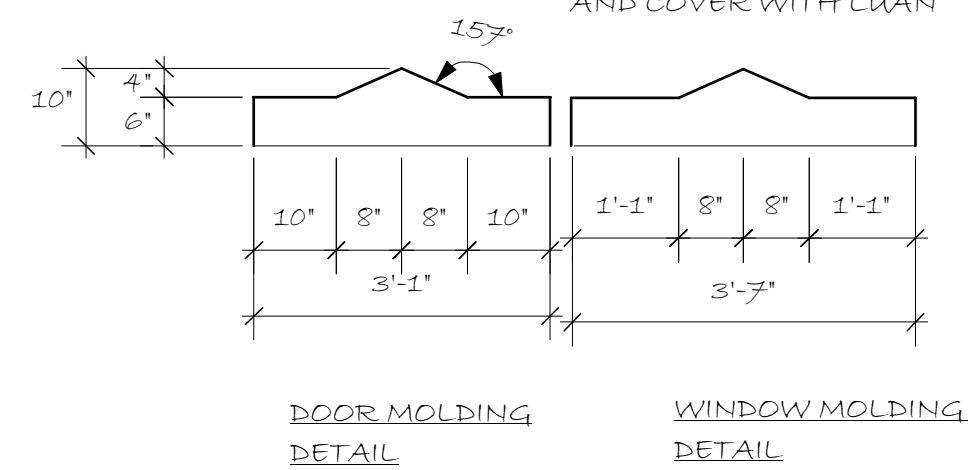

**DOOR MOLDING DETAIL**

**WINDOW MOLDING DETAIL**

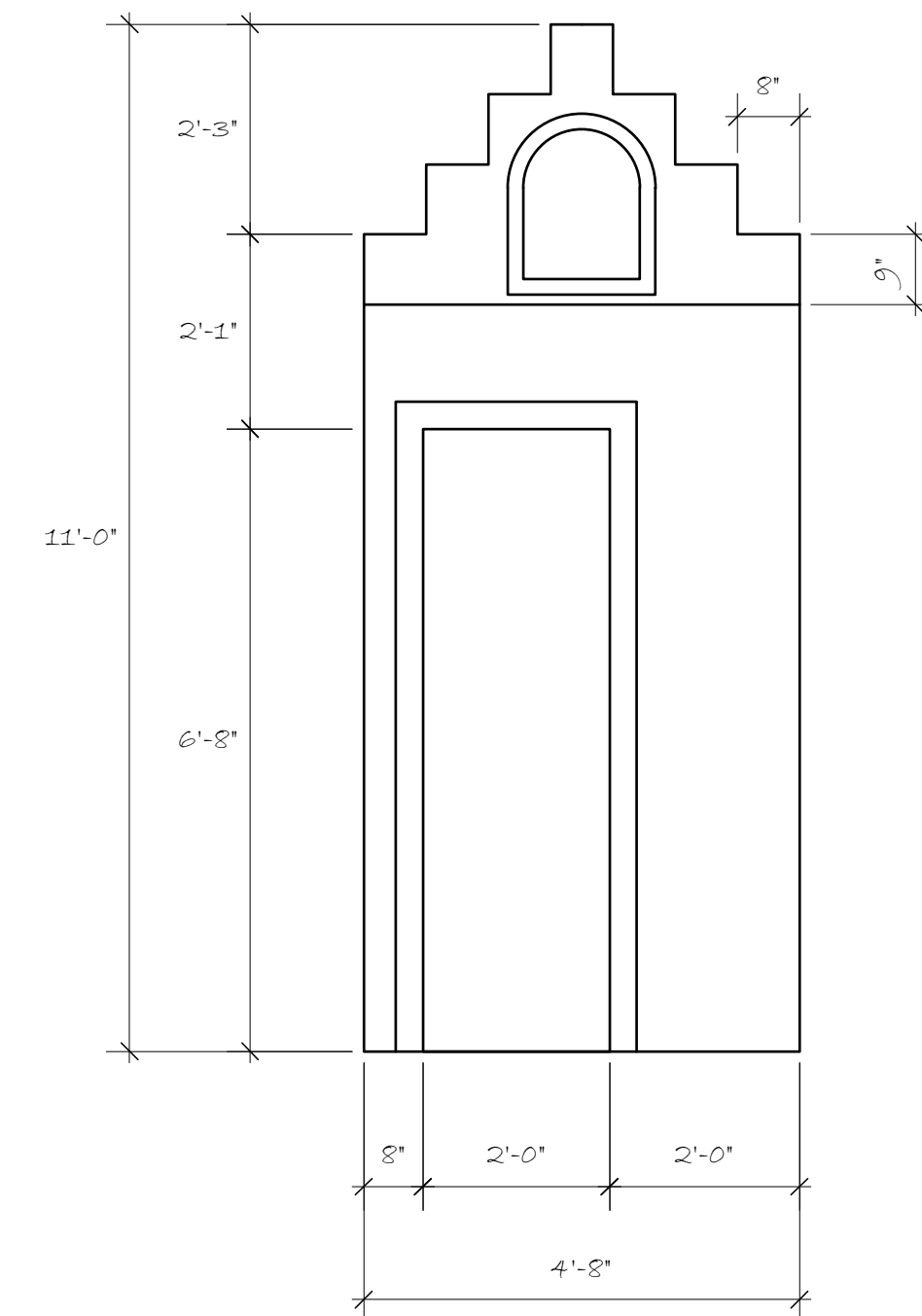

**BANK FASCADE**

NOTES: BUILD AS A HOLLYWOOD WINDOW AT TOP IS DECORATIVE. SEE DESIGNER FOR MOLDING & DOOR. FLAT COVERED WITH VACUFORM BRICKS

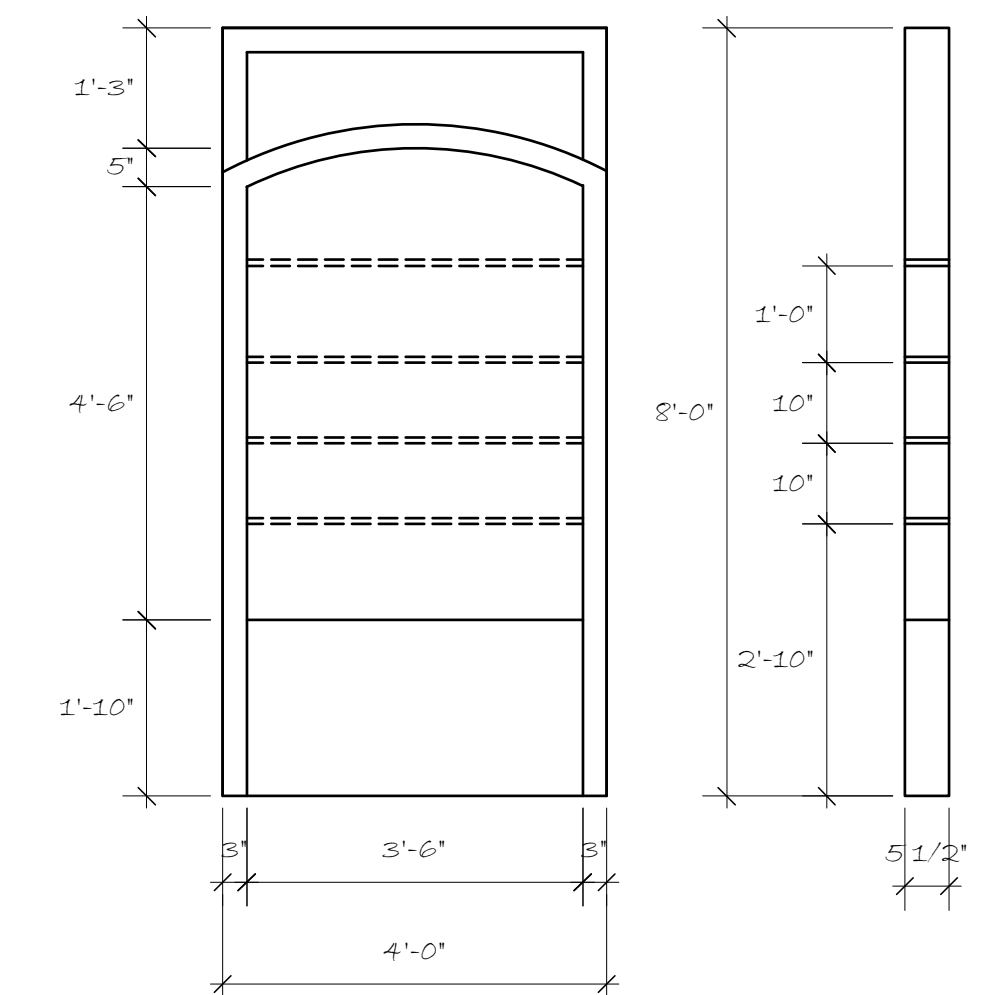

**FRONT VIEW**

**SIDE VIEW**

**BOOKSHELF**

NOTES: MUST BE ABLE TO FLY BOOKS ARE OUT OF VACUFORM AND MUST BE SECURELY ATTACHED. BUILD FIVE. BACKING CAN BE OUT OF LUAN OR CARDBOARD. SEE DESIGNER FOR MOLDING.

|                                    |                |
|------------------------------------|----------------|
| WWCC THEATRE                       |                |
| THE MUSIC MAN                      |                |
| ELEVATIONS                         |                |
| SCENE:                             | 13<br>OF<br>16 |
| DIRECTOR: C. WILL                  |                |
| SCENIC DESIGNER: A. CRITCHFIELD    |                |
| TECHNICAL DIRECTOR: A. CRITCHFIELD | SCALE: 1"=1/2" |
| 01/28/10                           |                |